

KLONDIKE SLED PLAN

Paint your sled bright colors. Varnish the bottom of the runners, and then apply wax before use. The Eskimos iced their runners. Add accessories of your choice – a canvas snow curtain as a snow guard front and sides will keep equipment dry. Use screws in place of nails, drill first to avoid splitting! Use exterior wood glue on all joints. Note: experience indicates that using an old pair of skis for runners makes the sled much easier to pull.

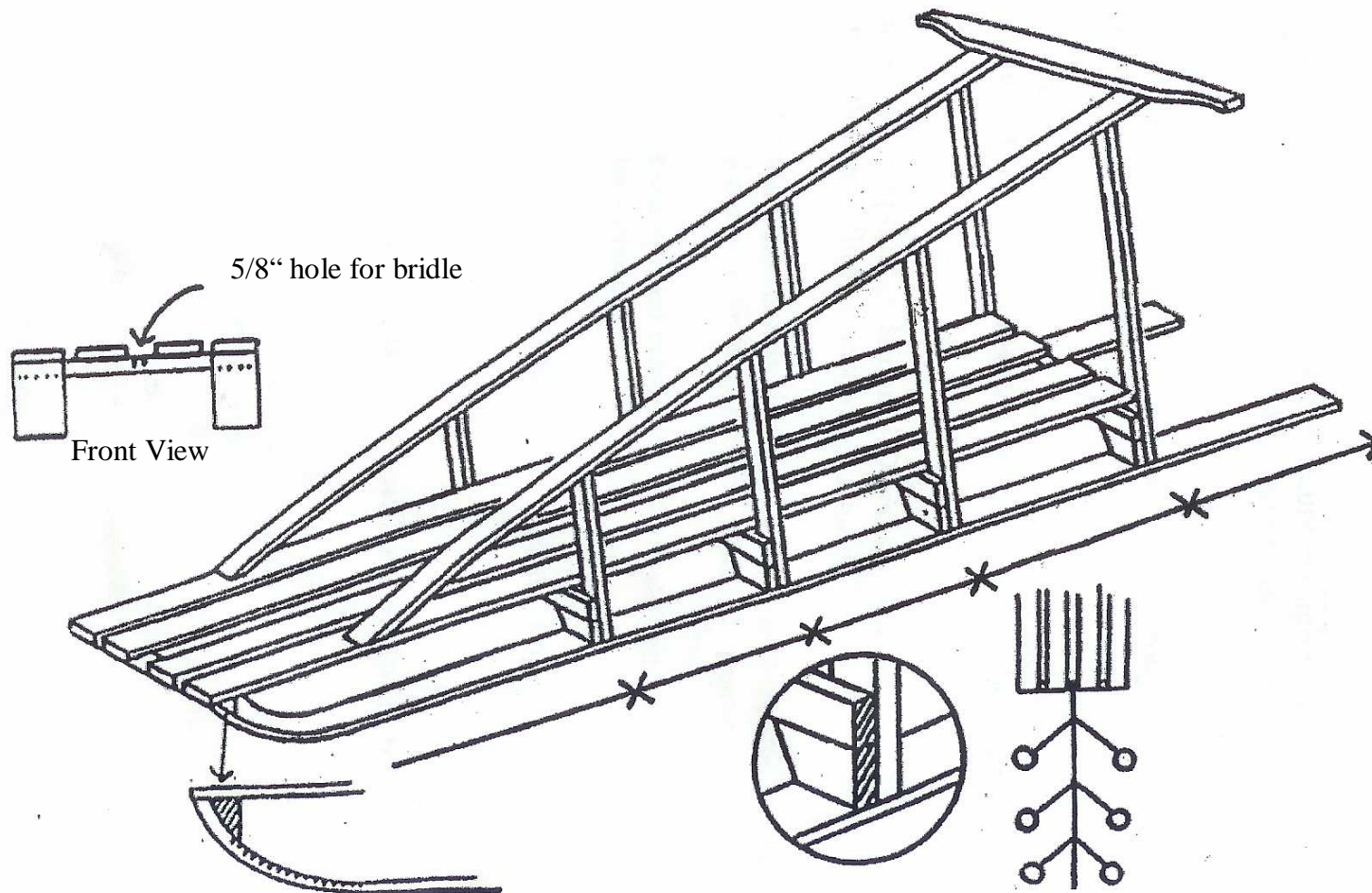

- ### Bill of Materials
- 2 pcs. 4" x 1/2" x 6'6"
Runner
 - 4 pcs. 1 x 1/2" x 18"
Cross Support
 - 4 pcs. 3/4" x 4" x 5"
Floor Cover
 - 8 pcs. 1" x 2" x 6"
Upright Support
 - 2 pcs. 1" x 2" x 40"
Rear Upright
 - 2 pcs. 1" x 2" x 38"
2nd Rear Upright
 - 2 pcs. 1" x 2" x 26"
2nd Front Upright
 - 2 pcs. 1" x 2" x 12"
Front Support
 - 2 pcs. 1/2" x 2" x 6"
Hand Rail
 - 1 pc. 1/2" x 2" x 30"
Front Curved Guard
 - 1 pc. 2" x 2" x 18"
Tow Bar
 - 1 pc. 1" x 3" x 30"
Pushing Handle